



LA20RPDC

Technical Product Data

Features

- **Amplifier Gain of 20dB**
Gain \geq 20dB
- **Extremely Flat Group Delay**
Less than 1ns Variation
- **Excellent Gain Flatness**
Gain $|L1 - L2| < 1.0$ dB

Description

The LA20RPDC GPS Line Amplifier is a one input, one output device with a 20dB min. gain block. The frequency response covers the GPS L1 & L2 bands with excellent flatness. In the normal configuration, the RF output (J1) passes DC from the connected GPS receiver through the amplifier to the antenna, allowing the GPS receiver to power both the antenna and the amp.

Electrical Specifications, $T_A = 25^{\circ}\text{C}$

Parameter	Conditions	Min	Typ	Max	Units
Freq. Range	Ant – J1	1.1		1.7	GHz
In/Out Imped. ⁽¹⁾	Ant, J1		50		Ω
Gain	Ant – J1	20	24.5	26	dB
Input SWR	J1 - 50 Ω			1.8:1	-
Output SWR	Ant - 50 Ω			1.8:1	-
Noise Figure	Ant – J1		3.3	3.5	dB
Gain Flatness	$ L1 - L2 $, Ant – J1		0.5	1	dB
Reverse Isolation	J1 – Ant	35			dB
Group Delay Flatness	$\tau_{d,max} - \tau_{d,min}$: Ant – J1			1	ns
Req. DC Input V.	Non-Network Configuration, DC Input on J1	3.6		15	Vdc
Current ⁽²⁾	Amplifier Current Draw, All prots - 50 Ω			15	mA

- (1). Input/Output Impedance = 75 Ω for 75 Ω connector option.
 (2). Current draw on J1 port in the non-networked configuration.

Available Options

Network Power Supply		
Source Voltage Options	VOLTAGE INPUT	STYLE
	110VAC	Transformer (Wall Mount)
	220 VAC	Transformer (Wall Mount)
	240 VAC (United Kingdom)	Transformer (Wall Mount)
Output Voltage Options ⁽¹⁾	Customer Supplied DC 8-28 VDC	Military Style Connector
	DC VOLTAGE OUT	MAX CURRENT OUT FOR CORRESPONDING Vout ⁽²⁾
	5 V	110mA
	7.5V	130mA
	9V	140mA
	12V	170mA
	15V	210mA
Custom	TDB	
Pass/Block DC Options		
Pass DC ⁽¹⁾	All Ports Pass DC	
DC Blocked ⁽¹⁾	Ant is DC blocked, Pass DC J1	
RF Connector Options		
Connector Options	CONNECTOR STYLE	CHARGE
	Type N	NC
	Type SMA	NC
	Type TNC	NC
Type N - 75Ω	Contact Sales Agent	

(1). With Network Option, any RF port (input or output) can be DC blocked or can pass the network DC voltage.

(2). $T_A = +50^{\circ}\text{C}$. Assuming Source of 110V, 220 or 240V Wall Mount Transformer. In general, maximum output current can be determined by:

$$I_{out} \leq 2.9 / (V_{sourceDC} - V_{out}) \text{ A}$$

Part Number

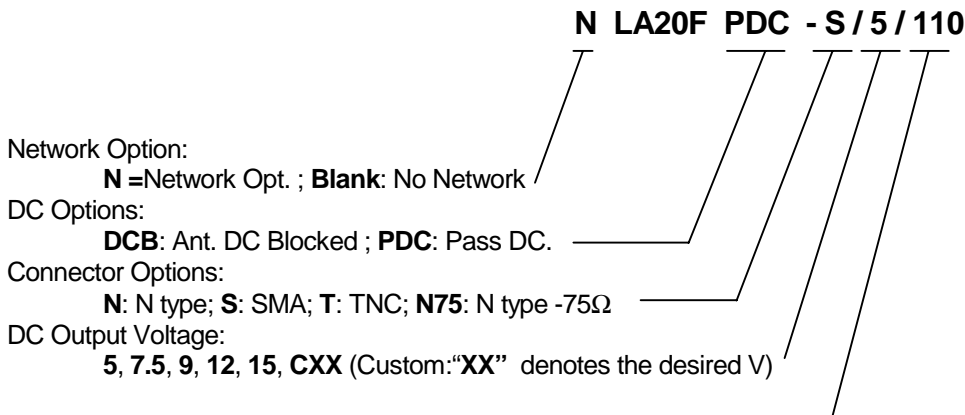

Source Voltage:

110 -Transformer, **220** – Transformer, **240** – Transformer, **MC** – Military Conn. (User supplies DV Voltage)

Performance

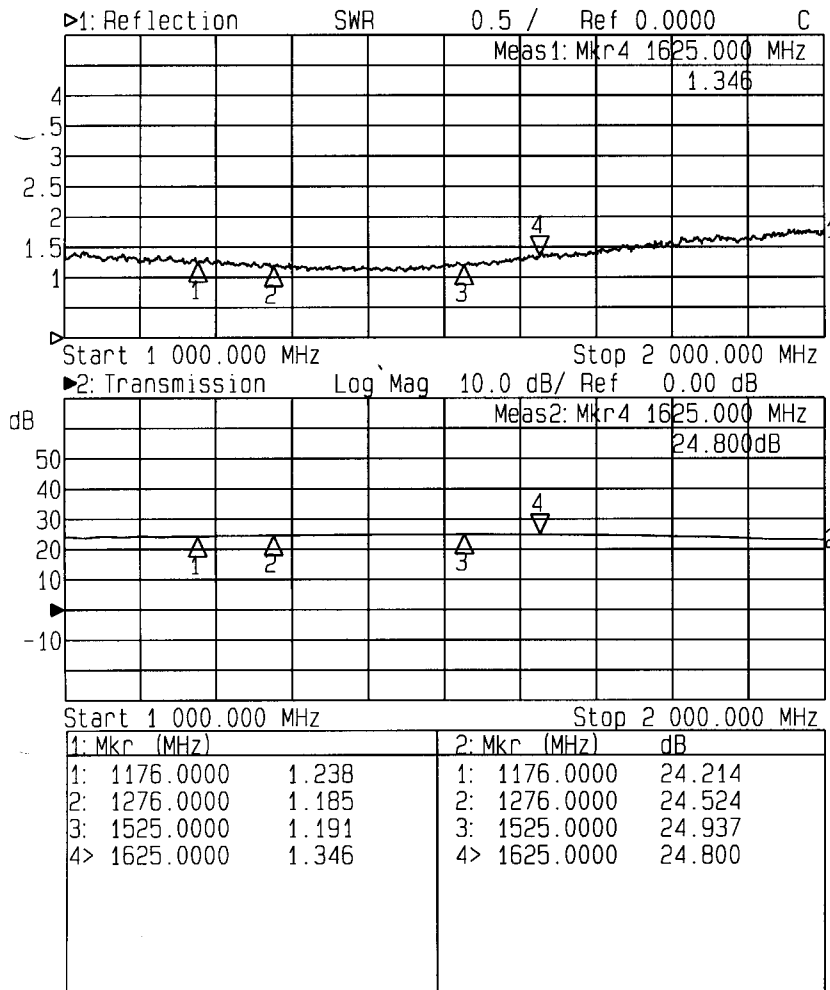

Input SWR (Ant. Port) and Frequency Response: Ant. To J1 (Typical, type N conn.):

Mechanical

Dimensions:

Height: 1.3"

Length (not including connectors) Body: 2.5"

Base Plate: 3.25"

Width: 2.5"

Weight: 10 oz. (286 grams)

Operating Temp. Range: -40° to + 75°C