



# Operation Manual

## CCD COLOR CAMERA

### CS6910G

#### Contents

#### **BEFORE USE - GENERAL SAFETY INSTRUCTIONS**

<b>1. Product Description</b>	1
<b>2. Features</b>	1
<b>3. Configuration</b>	1
<b>4. Option Unit</b>	2
<b>5. Connection example</b>	2
<b>6. Rear connector spec</b>	3
<b>7. Operation Mode</b>	4
<b>8. Timing Chart</b>	5
<b>9. Specifications</b>	6
<b>10. External View Drawing</b>	9
<b>11. Guarantee</b>	10
<b>12. Repair</b>	10



Thank you for purchasing our CCD color camera. This operation manual contains many important information such as how to use this product correctly and safely. Please read through this manual carefully. After reading, keep this manual by the side of this product for your future reference.

**TOSHIBA TELI CORPORATION**

## **BEFORE USE - GENERAL SAFETY INSTRUCTIONS**

Read the following safety precautions carefully before using this product. These instructions contain valuable information on safe and proper use that will prevent harm and damage to the operator and other persons. Make sure that you fully understand the following details (indications, graphic symbols) before proceeding to the remaining sections in this manual.

### **Indication definitions**



<b>Indication</b>	<b>Meaning</b>
 WARNING	This indicates the existence of a hazard that death or catastrophic bodily injury (*1) may result from improper use.
 CAUTION	This indicates the existence of a hazard that bodily injury (*2) or property damage (*3) may result from improper use.

\*1: Catastrophic bodily injury means loss of eyesight, burns (high and low temperature), shock, fracture, poisoning, etc. which leaves a sequela and require hospitalization or prolonged treatment.

\*2: Bodily injury means injuries, burns and electric shock which does not require hospitalization or prolonged treatment.

\*3: Property damage means extended harm to home, household effects, domesticated animals, and pets.

### **Graphic symbol definitions**

<b>Indication</b>	<b>Meaning</b>
 Should not do	This mark indicates a prohibited action that should not be carried out. The actual prohibited action is indicated in the symbol or nearby graphically or described in text.
 Must do	This mark indicates a mandatory action that must be carried out. The actual instruction is indicated in the symbol or nearby graphically or described in text.

## Handling Precautions

---

# WARNING

---



Unplug

- **Stop operation immediately when any abnormality or defect occurs.**  
Use during an abnormal condition; such as emitting smoke, burning odors, damage from dropping, invasion of water or foreign objects, etc. may cause fire and/or electric shock. Be always sure to disconnect the power cable from the wall socket at once and contact your dealer.
- 



Do not get wet

- **Do not operate in places with possibility of becoming wet.**  
This may cause fire and/or electric shock.
- 



NEVER pull  
apart

- **Do not repair, disassemble and/or modify by yourself.**  
This may cause fire and/or electric shock. Be always sure to contact your dealer for internal repair, check and cleaning of the product.
- 



Avoid

- **Don't place things or materials on the unit.**  
Ingress of foreign materials such as metallic things and liquid into the unit may cause a fire or an electric shock.
- 



Avoid

- **Do not put the product in an unstable, slanting and/or vibrated place.**  
Drop and/or fail of the product may cause injury.
- 



Do not touch

- **Do not touch the power cable and the connection cables during a thunderstorm**  
This might cause electric shock.
- 



Instruction

- **Use the specified power supply.**  
Use of an unspecified power supply may result in fire or electric shock.
- 



Avoid

- **Do not be handled roughly, damaged, fabricated, bent forcefully, pulled, twisted, bundled, placed under heavy objects or heated the power cable and the connection cable.**  
Otherwise, fire or electric shock may result.

## Handling Precautions

---

# CAUTION

---



Instruction

- **Note the following instructions when install.**  
-Do not wrap the product in a cloth, etc.  
-Do not install the product in a narrow space where is hard to emit heat.  
If you do not follow the above, the heat generated by the product may cause fire.
- 



Avoid

- **Avoid setting in humid, smoky, vaporized or dusty places. A fire or an electric shock may occur in such places.**  
This may cause fire and/or electric shock.
- 



Avoid

- **Do not put the product in direct sunshine and/or high temperature.**  
The temperature inside the product may cause fire.
- 



Instruction

- **Use the specified DC power cable and connection cable.**  
Otherwise, a fire or an electric shock may occur.
- 



Instruction

- **Turn OFF the power in the case of connection.**  
Turn OFF the power when connect power cable or connection cable to the product.  
Otherwise, an electric shock or a malfunction may occur.
- 



Avoid

- **Do not expose its camera head to any intensive light (such as direct sunlight).**  
Otherwise, its inner image pickup device might get damaged.
- 



Avoid

- **Avoid short-circuiting signal output.**  
Otherwise, a malfunction may occur.
- 



Avoid

- **Avoid giving a strong shock against the camera body.**  
It might cause a breakdown or damage.  
If your camera is used in a system that its camera connector part is subjected to strong repetitive shocks, its connector may break down. If you intend to use your camera in such a system, as much as possible bundle and fix a camera cable in the place nearer the camera, and do not transmit a shock to the camera connector.
- 



Instruction

- **Ask your dealer to perform a periodical inspection and internal cleaning (approx. every five years).**  
Dust inside the product may cause fire and/or trouble. Please consult your dealer for inspection and cleaning cost.

---

## **RESTRICTION FOR USE**

---

- Should the equipment be used in the following conditions or environments, give consideration to safety measures and inform us of such usage:
  1. Use of the equipment in the conditions or environment contrary to those specified, or use outdoors.
  2. Use of the equipment in applications expected to cause potential hazard to people or property, which require special safety measures to be adopted.
- This product can be used under diverse operating conditions. Determination of applicability of equipment or devices concerned shall be determined after analysis or testing as necessary by the designer of such equipment or devices, or personnel related to the specifications. Such designer or personnel shall assure the performance and safety of the equipment or devices.
- This product is not designed or manufactured to be used for control of equipment directly concerned with human life (\*1) or equipment relating to maintenance of public services/functions involving factors of safety (\*2). Therefore, the product shall not be used for such applications.
  - (\*1): Equipment directly concerned with human life refers to.
    - Medical equipment such as life-support systems, equipment for operating rooms.
    - Exhaust control equipment for exhaust gases such as toxic fumes or smoke.
    - Equipment mandatory to be installed by various laws and regulations such as the Fire Act or Building Standard Law
    - Equipment related to the above.
  - (\*2): Equipment relating to maintenance of public services/functions involving factors of safety refers to.
    - Traffic control systems for air transportations, railways, roads, or marine transportation
    - Equipment for nuclear power generation
    - Equipment related to the above

---

## **DISCLAIMER (LIMITED WARRANTY)**

---

We disclaim any responsibility and shall be held harmless for any damages or losses incurred by the user in any of the following cases;

- Fire, earthquake or any other act of God; acts by third parties; misuse by the user, whether intentional or accidental; use under extreme operating conditions.
- Malfunction or non-function resulting in indirect, additional or consequential damages, including but not limited to loss of expected income and suspension of business activities.
- The damage by incorrect usage that is not in compliance with instructions in this instruction specifications and manual.
- The damage that occurred by the operation method that is not mentioned in specifications and manual.
- Malfunctions that result by incorrect connection with other equipment (software or connected equipments including image processing board, the lens, etc.) which be not concerned with us.
- Repairs or modifications made by the user or caused to be made by the user and carried out by an unauthorized third party (such as an unauthorized service representative).
- Notwithstanding the foregoing, Teli's liabilities shall not, in any circumstances, exceed the purchase price of the product.
- About items which are not mentioned of this product's instruction manual and specifications, it considers as the outside of object of guarantee.

---

## CAUTIONS ON USE

---

- Carefully handle the units.

Do not drop, or give a strong shock or vibration to the camera. This may cause problems. Treat the camera cables carefully to prevent cable problems, such as cable breakdown and loosened connections.

- Operating ambient temperature and humidity.

Do not use the camera in places where temperature and humidity exceed the specifications. Picture quality will lower and internal parts may be damaged.

Be particularly careful when using in places exposed to direct sunlight. When shooting in hot or cold places, depending on the conditions of the object and the camera (for example when the gain is increased), vertical strip noise or white dots may occur. This is not a malfunction.

- Regarding a lens mount.

Install a next lens; the C mount lens, its dimension of protrusion from flange is equal to or less than 10.5mm. If a lens does not stand to this condition, it might not be installed to this camera.

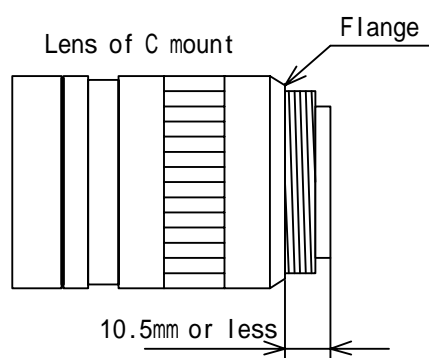

- Restriction for the lens combination

This camera might form a ghost to image area depending on the combination of a lens and an illumination with this camera. But this is not a failure of this camera.

In addition, performance of the camera might be not shown enough due to resolution of a penumbra and drop of brightness, distortion etc cause depend on use lens.

Please confirm a combination of this camera with the lens and the illumination to use.

When mounting a lens, take extra caution so that the lens is not tilted, nor does flaw exist at the lens-mount-screw part. Also check to confirm that no dirt nor other foreign object is put inside.

Improper mounting might cause the parts to become locked.

- Do not shoot under intense light.

Avoid intense light such as spot light on part of the screen because it may cause blooming or smears. If intense light falls on the screen, vertical stripes may appear on the screen, but this is not a malfunction.

- Do not expose the camera's image-pickup-plane to sunlight or other intense light directly.

Its inner CCD (charge-coupled device) might be damaged.

- Moire

When thin stripe patterns are shot, stripe patterns that are not actually there (moire) may appear as interference stripes. This is not a malfunction.

---

## CAUTIONS ON USE

---

- Undesirable noise

If the camera or the cables are located near something which emit strong magnetism or near something which emit strong electric wave, undesirable noise may appear on the screen. In such a case, try to change the location of the camera or the cable wiring.

- Handling of the protection cap

When the camera is not in use, put a lens-cap onto the camera head for protection of the image-pickup-plane.

- When not using the camera for a longtime.

Stop supplying power for safety.

- When cleaning the camera

Always turn off the power and clean with a piece of soft dry cloth.

To remove stubborn stains, use a soft cloth soaked in diluted acid-free detergent. Do not use alcohol, benzine, thinner, etc. If used, coating and printed letters may be discolored.

In case the image-pickup-plane should be settled with fine dust, dirt, or scratched, ask your dealer for technical advice.

- When disposing of the camera.

Wastes of this product should be separated and discarded in compliance with the various national and local ordinances.

This camera is showing the following symbol to body due to EU environmental regulation (Waste Electrical and Electronic Equipment (WEEE)). However this symbol is applied to only a EU member state.



## 1. PRODUCT DESCRIPTION

This camera is Gigabit Ethernet output, integral-type high frame rate color camera adopting CCD with 630,000 effective pixels.

## 2. FEATURES

### (1) High resolution

CCD with 630,000 effective pixels is adopted. Image processing embedded in the camera allows high-resolution 24-bit color images in a SXGA (1280 x 960) size.

### (2) Full frame output

All pixel information is outputted through progressive scan even in random trigger shutter.

### (3) High frame rate

SXGA (1280 x 960) images can be outputted in high speed; 30 frames/sec.

### (4) Random Trigger Shutter function (RTS)

The random trigger shutter function provides images in any timing by input of an external trigger signal.

### (5) Gigabit Ethernet I/F

The Gigabit Ethernet is adopted for video output and camera control interfaces. Gigabit Ethernet allows high-speed transfer of images to PC and control camera from PC.

### (6) Compact and light-weight

This camera is compact and lightweight with outside dimensions of 54(W) x 43(H) x 94.5(D) mm (include lens mount parts) and weight of approximately 180g. It is easy to integrate into industrial equipment.

\* Ethernet® is a registered trademark of XEROX Corporation.

## 3. CONFIGURATION

(1) Camera body ..... 1

### (2) Accessory

- Operation Manual (Japanese) ..... 1

- Operation Manual (English) ..... 1

- CD ..... 1

    | Operation Manual (Japanese / English)

    | Interface Specifications (Japanese / English)

    | SDK

    | Sample Viewer

\* To operate this color camera, user must install SDK.

## 4. OPTION UNIT

- Power cable (2m / 3m / 5m) CPRC3700-\*\*
- Tripod mount CPT4000CL
- Camera adapter CA130C,CA150 (\*1)

(\*1) CA150 does not support trigger input. To use the external trigger function, CA130C is required.

[Compliance with EMC standard]

The compliance of this device to the EMC standard is guaranteed in the condition with the optional parts above. If you use this product combined with parts other than specified by us, the customer should check the EMC compliance of the entire machine/device.

## 5. Connection example

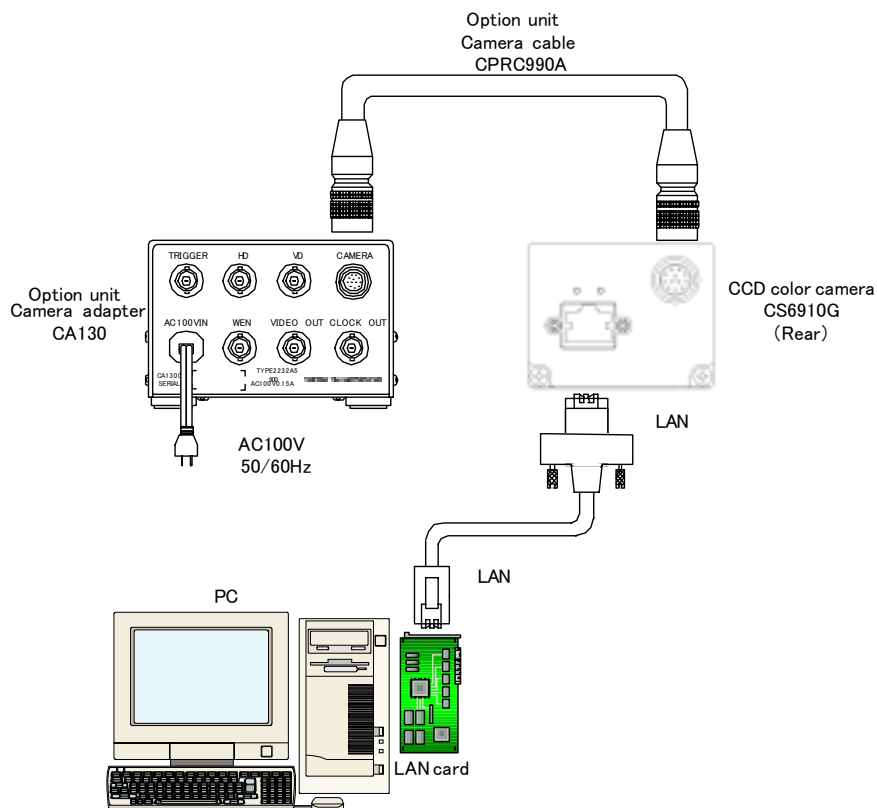

## 6. Rear connector spec

### 1. Ethernet Gigabit Ethernet interface connector

Pin assignment

Pin No.	I/O	Function
1	I/O	BI_DA+
2	I/O	BI_DA-
3	I/O	BI_DB+
4	I/O	BI_DC+
5	I/O	BI_DC-
6	I/O	BI_DB-
7	I/O	BI_DD+
8	I/O	BI_DD-

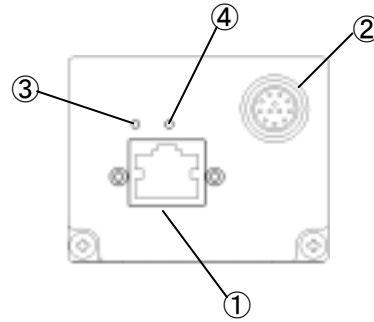

### 2. DC IN/TRIGGER Power supply / Trigger input connector

Compatible connector HR10A-10P-12S (Supplied by HIROSE ELECTRIC CO., LTD.)

Pin assignment

Pin No.	Signal name [Standard specification]
1	GND
2	DC12V
3	GND
4	NC
5	GND
6	NC
7	VD OUT
8	NC
9	NC
10	NC
11	TRIG IN
12	GND

Connector pin assignment

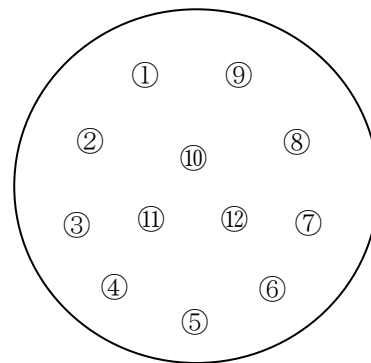

12pins (plug)

\*note

The figure mentioned above shows the case that watched a connector from the fit side.

Notes: \*Before connecting / disconnecting the connector, make sure the camera power is OFF.

\*\*For board connection, check compatibility.

3. Indication LED1 (LINK LED) Shows a state of LINK

4. Indication LED2 (ACT LED) Shows a state of ACT

During link : LINK LED (Green) Lighting

ACT LED (Orange) Lighting

During transfer: LINK LED (Green) Lighting

ACT LED (Orange) Blinking

\*LINK LED indicates establishment of Link of 1000BASE. Therefore, in the case of 100BASE/10BASE, LINK LED does not light.

## 7. Function

This camera can control following each functions by camera control in Gigabit Ethernet interface.

(1)Video output format selection	SXGA FULL RGB SXGA HALF RGB VGA FULL RGB
(2)Shutter mode selection	Manual / Auto
(3)Auto Exposure (AE) Operation setting	detect range setting AE Lock Exposure correction level setting
(4)Random Trigger Shutter Operation setting	Random Trigger Enable/Disable (Normal shutter) Trigger Polarity Positive / Negative Pulse width control mode / Exposure time fixed mode
(5)White Balance (WB) Operation setting	Full Auto (AWB) One Touch Auto (OTWB) Manual (MWB) Manual color temperature value setting R, B Gain value setting
(6) $\gamma$ characteristic selection	0.45 / 0.65 / 1.0 / User settings
(7)Edge Enhancement Setting	Edge Enhancement level setting
(8)Set value memory control	Save / Load / Reset
(9)Read-out of each camera information	
(10)Image resending control	Loss packet resending

\* The details are mentioned in “Interface Specifications”.

## 8. TIMING CHART

Image data output of Model CS6910G use UDP of Gigabit Ethernet. Timing numerical value below is prescribed by absolute prerequisite that CS6910G use transmission band without restriction of other node. When there is a node transferring with CS6910G concerned, it is not same the numerical value prescribed below.

### (1) Normal shutter mode

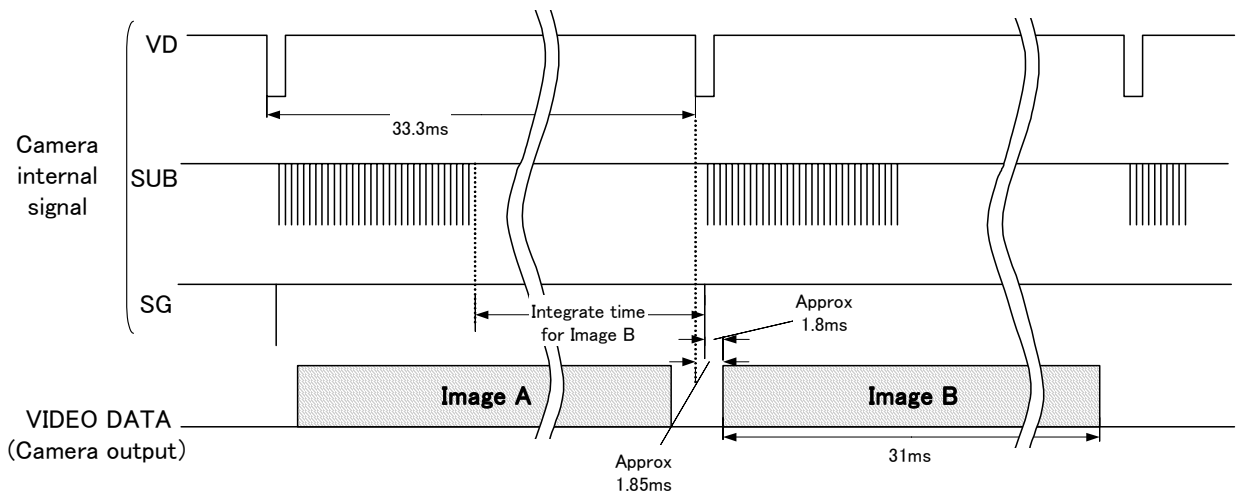

### (2) Random Trigger Shutter mode (Exposure time fixed)

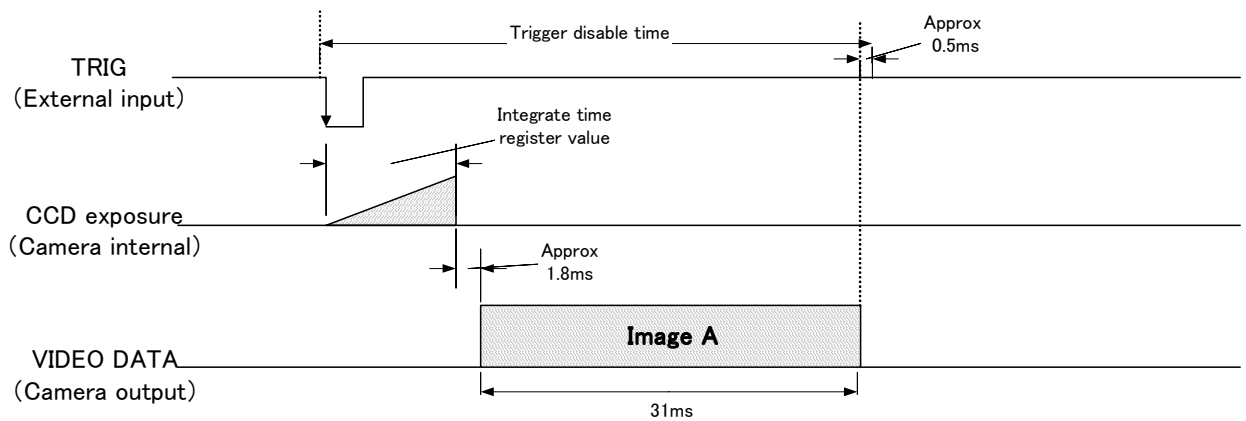

\*Delay time of camera processing against trigger input signal is some 1.5 $\mu$ s.

### (3) Random Trigger Shutter mode (Pulse width control)

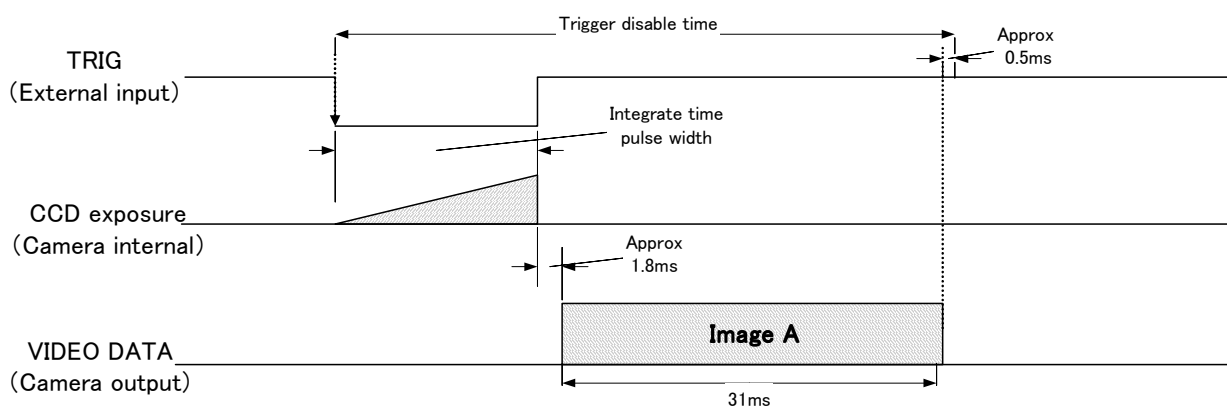

\*Delay time of camera processing against trigger input signal is some 1.5 $\mu$ s.

## 9. SPECIFICATIONS

### [Basic spec]

- |                                  |   |
|----------------------------------|---|
| (1) Image sensor                 | CCD   |
| 1. Readout method                | All pixels data simultaneous readout                      |
| 2. Total number of pixels        | 680(H) x 504(V) x 2 (685,440 pixels)                      |
| 3. Number of effective pixels    | 648(H) x 486(V) x 2 (629,856 pixels)                      |
| 4. Unit cell size                | 3.8 x 3.8 $\mu$ m   |
| 5. Area size of effective pixels | 3.4992(H) x 2.6244(V) mm                                  |
| 6. Chip size                     | 5.0(H) x 4.53(V) mm (1/4.2 type)                          |
| 7. Color filter                  | G square grid array, R / B interpolation point sequential |
| 8. Driving frequency             | 24.5454MHz  |

### (2) Image format

Mode	Output method	Frame rate	Output image pixel numbers
SXGA FULL RGB	RGB 24bit digital	30 fps	1280(H) x 960(V)
SXGA HALF RGB	RGB 24bit digital	15 fps	1280(H) x 960(V)
VGA FULL RGB	RGB 24bit digital	30 fps	640(H) x 480(V)

### (3) Sync system

Internal synchronization

### (4) Aspect ratio

4: 3

### (5) Video output

- |                      |   |
|----------------------|---|
| 1. Interface method  | Gigabit Ethernet IEEE802.3ab (1000BASE-T) conformity  |
| 2. Transfer rate     | 1Gbps (maximum)   |
| 3. Conformity cable  | Twist pair (Category 5e or over)  |
| 4. Recommended cable | MOD-YSP-A( )S-S(+)<br>(Supplied by HONDA TSUSHIN KOGYO CO., LTD.:<br>Industrial high flexibility cable) |

\* Because above recommendation cable is Category 5, maximum length of cable is 30m.

- |                    |   |
|--------------------|---|
| 5. Length of cable | To 100m (at the time of Unshielded Twist Pair(UTP) cable use) |
|--------------------|---|

(6) S/N	50dB (Edge enhancement: OFF, $\gamma$ : 1, based on our bench mark)
(7) Subject illumination	3000lx, F8, 5100K (SXGA FULL, Shutter speed: 1/30s)
(8) Minimum subject illumination	30lx, F1.4 (SXGA FULL, Shutter speed: 1/30s, $\gamma$ : 0.45, Gain: +6dB, Video level: 50%)
(9) Gain control	Analog pre-gain control available Control range: 0 to +6dB
(10) $\gamma$ correction	0.45 / 0.65 / 1.0 / User setting(1 type)
(11) White Balance	
1. Full Auto	
- Operation method	Area-by-area white determination tracking method
- Divide area	All area 8 x 8 divided equally
- Effective color temperature	2400K to 6500K
- Effective area	All areas that can recognize white
	* Full Auto at RTS setting is invalid.
2. One Touch	
- Effective temperature	2400K to 9000K
- Effective area	All area
	* One Touch at RTS setting is invalid.
3. Manual	
- Setting color temperature	3000 / 3700 / 4000 / 4500 / 5500 / 6500K (Preset setting) R , B gains can be set separately
(12) Edge enhancement	Intensity 7 levels and Enhancement OFF can be set. Horizontal-vertical both edge enhancement
(13) Power source	DC12V $\pm$ 10% (voltage: 100mV (p-p) or less for ripple)
(14) Power consumption	7W or less
<b>[Internal sync spec]</b>	
(1) Base clock frequency	24.576 MHz
(2) H sync frequency	15.75 kHz
(3) V sync frequency	30.00 Hz
<b>[Shutter trigger spec]</b>	
(1) Input level	Low: 0 to 0.5V High: 2.0 to 5.0V
(2) Input impedance	High impedance
(3) Capture timing	Positive / Negative    Bipolar
<b>[Output signal spec]</b>	
(1) Output signal	VD
(2) Output level	LVTTL
(3) Polarity	Negative
(4) Repeating frequency	29.97Hz (SXGA 30fps / VGA 30fps) 14.98Hz (SXGA 15fps)

## [Electronic shutter spec]

### (1) Normal shutter

#### 1. Auto Exposure (AE)

- Detect area Center-weighted average metering / Spot metering
- Tracking range 1/15000 to 1/30s (SXGA FULL / VGA FULL)  
1/10000 to 1/15s (SXGA HALF)

\* AE at RTS setting is invalid.

#### 2. Manual setting

- Exposure time 1/15000 to 4s (SXGA FULL / VGA FULL)  
1/10000 to 4s (SXGA HALF)
- Setting precision Set by a/b[s] (a: 1 to 4, b: 1 to 15000, can be set for 1 step)

\* When exposure time is set up for a long time, white spots and the unevenness of a highlight portion might occasionally be observed on screen. This phenomenon is due to the characteristics of the CCD image sensor.

### (2) Random Trigger Shutter

- Operation mode Pulse width control mode / Exposure time fixed mode
- Trigger Polarity Positive / Negative Bipolar

## [Mechanical spec]

- (1) External dimension 54(W) x 43(H) x 94.5(D) mm
- (2) Weight approximately 180g
- (3) Lens mount C mount
- (4) Flange focal distance 17.526mm
- (5) GND / insulation Circuit GND - Chassis electrically conducted

## [Operating environment]

### (1) Ambient condition

- 1. Performance guaranteed Temperature/Humidity 0 to +40 / 20 to 80%RH (Without condensation)
- 2. Operation guaranteed Temperature/Humidity 0 to +45 / 20 to 80%RH (Without condensation)
- 3. Storage Temperature/Humidity -20 to +60 / 20 to 95%RH (Without condensation)

- (2) Conformity standard EN61000-6-4/2001  
EN61000-6-2/2001  
FCC part15 class A

### 【Conformity of EMC conditions】

About the conformity of the EMC standard of this machine, it has guaranteed in the conditions combined with the option part of 4th clause. When used combining parts other than specification of our company, I ask you to have final EMC conformity checked of a visitor with a machine and the whole equipment.

# 10. EXTERNAL-VIEW DRAWING

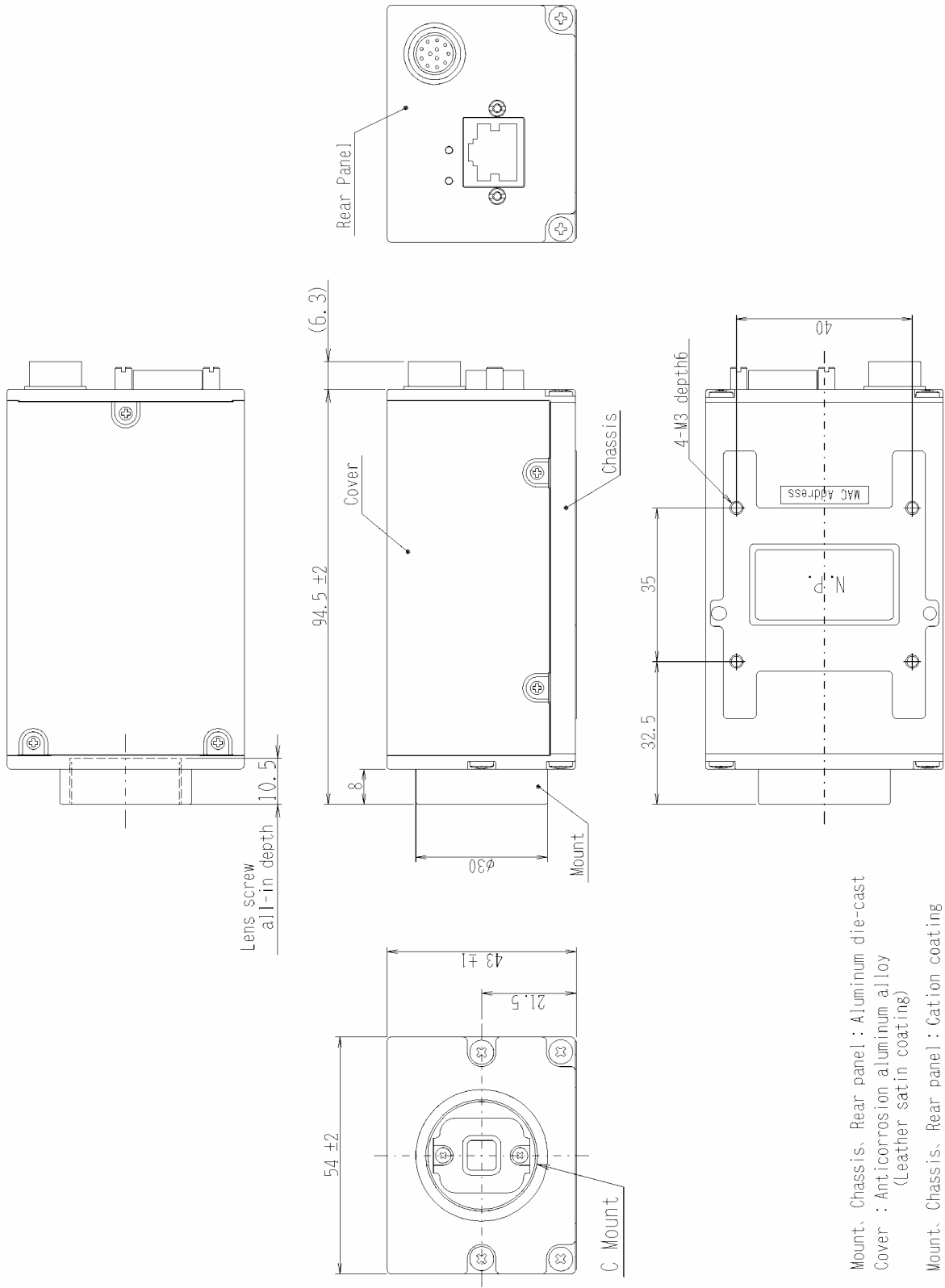

Specification  
Material

Mount, Chassis, Rear panel : Aluminum die-cast  
Cover : Anticorrosion aluminum alloy  
(Leather satin coating)

Processing

Mount, Chassis, Rear panel : Cation coating

## **11. Guarantee**

(1) The term of a guarantee

The term of a guarantee is one year after the product delivery.

(2) Scope of guarantee.

- If by any chance trouble by responsibility of our company occurs before an above period, TELI repairs it free of charge.
- During terms of a guarantee, when the trouble cause is the case of below, TELI charges the repair costs.
  - 1) Troubles and the damages that causes by misuse, unsuitable repair or remodeling.
  - 2) Distribution hazards like drops and vibrations after purchase. Troubles and damages by transportation.
  - 3) Troubles and damages by fire, natural calamity (earthquake, storm and flood damage, thunderbolt), damages from salty breeze, gas harm, abnormal voltage.

## **12. Repair**

(1) Condition for repair

Basically, has to return it to our company when the user requests us to repair product.

Beside that, customer should pay these expenses (travel expenses, camera disassembly technology costs) of both customer and end user. Also customer should pay in themselves costs for return camera to us.

(2) The period of repairing product

- Repair free of charge

Refer to Clause 11.

- Charged repair

Basically, repair period is 7 years after the last production end of products.

note



## **TOSHIBA TELI CORPORATION**

---

Head Office: 7-1, 4 chome, Asahigaoka, Hino-shi, Tokyo, 191-0065, Japan

(Overseas Sales Department)

Phone: +81-42-589-8771 Fax: +81-42-589-8774

URL: <http://www.toshiba-teli.co.jp>

---

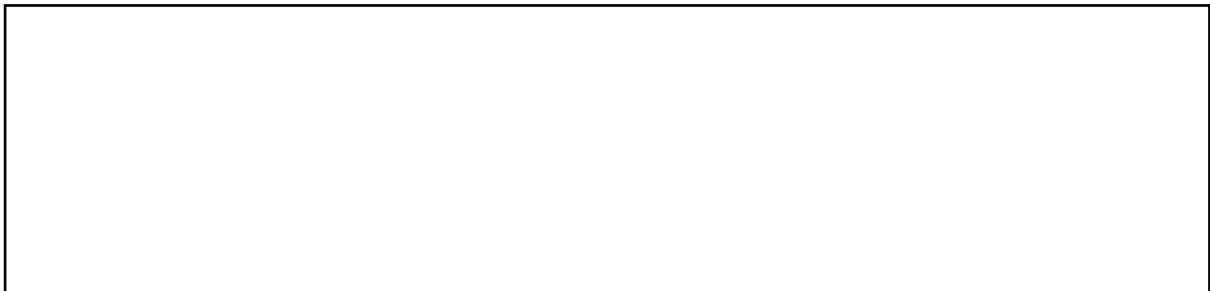

The design and specification is subject to change without notice.