

Acutime Gold

GPS Smart Antenna for Precise Timing and Synchronization

Key Features and Benefits

- RoHS compliant
- Stratum 1 time source
- Network synchronization
- Timing pulse synchronized to within 15 nanoseconds (one sigma) of GPS/UTC
- Operating temp -40° to +85°C
- Waterproof and corrosion resistant housing

Trimble's Acutime™ Gold GPS smart antenna marks the integration of the latest DSP based software GPS technology into a rugged self-contained unit that enables easy integration into any system. The Acutime Gold is a pole-mounted GPS receiver and antenna in a single environmentally sealed enclosure.

The Acutime Gold GPS smart antenna design continues Trimble's line of GPS smart antennas, which have been in production since 1991. This antenna is the perfect solution for precise timing and network synchronization needs, including broadband wireless applications. It provides an extremely cost-effective and independent (within the firewall) timing source for any application, such as fault detection systems and synchronization of wireless networks.

Once power is applied, the Acutime Gold automatically tracks satellites and surveys its position to within meters. It then switches to overdetermined time mode and generates a pulse-per-second (PPS) output synchronized to UTC within 15 nanoseconds (one sigma), outputting a time tag for each pulse. The Acutime Gold GPS smart antenna's T-RAIM (Time-



The Acutime Gold is the premier time source for synchronization of wireless networks.

Receiver Autonomous Integrity Monitor) algorithm ensures PPS integrity.

Designed for long-term reliability, the Acutime Gold GPS smart antenna is corrosion-resistant and waterproof, and has a rounded top that facilitates run-off from the elements.

Physical Interface

The RS-422 interface is ideal for long cable runs required by buildings or towers. Standard cables are available in lengths up

to 400 feet. Custom lengths up to 1800 feet may be ordered.

Getting Started

The Acutime Gold Starter Kit makes it easy to evaluate the exceptional performance of this GPS smart antenna and integrate state-of-the-art technology into your system. The Starter Kit includes the Acutime Gold GPS smart antenna (RS-422), a 100' interface cable, user guide, RS-422 to USB converter, and a Windows software tool for monitoring and communication.

Trimble

Acutime Gold

GPS Smart Antenna for Precise Timing and Synchronization

PHYSICAL CHARACTERISTICS

Dimensions: 3.74" D, 2.85" H (95mm x 72.5mm)
Weight: 5.4 oz (154 g)
Connector: 12-pin round, waterproof
Mounting: 1"-14 straight thread or 3/4" pipe thread
Mechanical drawing:

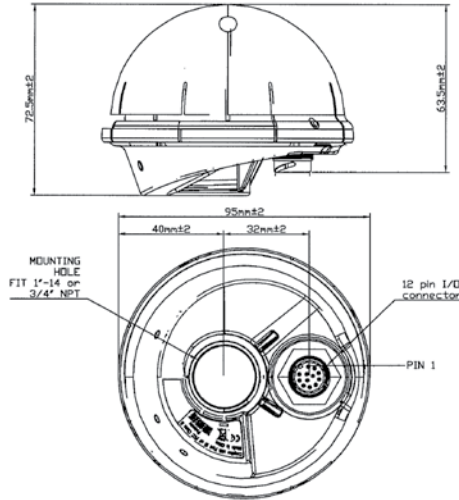

ENVIRONMENTAL SPECIFICATIONS

Operating temp: -40° to +85° C
Storage temp: -55° to +105° C
Vibration: 0.008 g²/Hz 5 Hz to 20 Hz
 0.05 g²/Hz 20 Hz to 100 Hz
 -3dB/octave 100 Hz to 900 Hz
Operating humidity: 95% RH, non-condensing @ 60° C
EMC: CE, FCC Class B

PERFORMANCE SPECIFICATIONS

General: L1 frequency, C/A code (SPS), continuous tracking receiver, static overdetermined clock mode (default).
Update Rate: 1Hz
Accuracy
Horizontal Position: <6 meters (50%) <9 meters (90%)
Accuracy
Altitude Position: <11 meters (50%) <18 meters (90%)
Velocity: 0.06 m/sec
Time to First Fix (no stored position): <46 sec. (50%), <50 sec. (90%)
Time to First PPS (stationary with stored position, e.g., recovery after power outage): <14 sec. (50%), <18 sec. (90%)
Re-acquisition after 60-second signal loss: <2 sec. (90%)

Dynamics

Velocity: 500 m/sec maximum
Acceleration: 4g (39.2 m/sec²)
Jerk: 20 m/sec³

PPS output

Physical Interface: RS-422
Width: 10 microseconds (default); user-programmable from 10 microseconds to 500 milliseconds
On-Time Edge: Rising edge on-time (default); user-programmable rising or falling
Resolution: 80 nanoseconds (quantization error reported through TSIP)
Accuracy (one sigma): UTC 15 nanoseconds (static)
 UTC 90 nanoseconds (dynamic, TDOP ≤3)

External Event Capture

Interface: RS-422
Resolution: 488 nanoseconds

Minimum

pulse width: 1 microsecond, rising edge on-time
Reporting mechanism: TSIP packet

ELECTRICAL SPECIFICATIONS

Prime power: +5 VDC* to +36 VDC, reverse polarity protection
Power consumption: 110mA @ 12 volts, 1.3 watts (typical), <1.5 watts max
 * reduced cable length @ +5 VDC to +12 VDC

SERIAL PROTOCOLS

Port	Interface	Protocols	Defaults
TxB (primary)	RS-422	TSIP, NMEA	TSIP @ 9600, 8-odd-1
RxB (primary)	RS-422	TSIP	TSIP @ 9600, 8-odd-1
TxA (secondary)	RS-422	TSIP	TSIP @ 9600, 8-odd-1
RxA (secondary)	RS-422	Event/RTCM	Event

All ports support baud rates of 115,200–38,400; 8 data bits; even, odd, no parity

NMEA messages: GGA, GLL, VTG, GSV, GSA, ZDA, RMC

ORDERING INFORMATION & ACCESSORIES

Please visit our website for updated information, part numbers and ordering information at: www.trimble.com/timing

Specifications subject to change without notice



Trimble Navigation Limited is not responsible for the operation or failure of operation of GPS satellites or the availability of GPS satellite signals.