

FRAMOS Electronic Vertriebs GmbH

Zugspitzstrasse 5 - Haus C
 82049 Pullach near Munich
 Tel. 0049 - 89 - 710 667 0
 Fax. 0049 - 89 - 710 667 66

Email: info@framos.de

ALDCBS1X4

Technical Product Data

Features

- **Amplifier Gain of 17dB**
Gain ≥ 17 dB
- **Extremely Flat Group Delay**
Less than 1ns variation
- **Phase Matched Outputs**
Phase (J1 – J2) $< 1.0^\circ$

Description

The ALDCBS1X4 GPS Amplified Splitter is a one input, four output device with a 17dB min. gain block. The frequency response covers the GPS L1 & L2 bands with excellent gain flatness. In the normal configuration, one of the splitter RF outputs (J1) passes DC from the connected GPS receiver through the splitter to the antenna, allowing the GPS receiver to power both the antenna and the splitter amp. The other RF outputs (J2, J3, J4) are DC loaded with a 200 Ω resistor to simulate the antenna current draw.

Electrical Specifications, $T_A = 25^\circ\text{C}$

Parameter	Conditions	Min	Typ	Max	Units
Freq. Range	Ant – Any Output, Unused Outputs - 50 Ω	1.1		1.7	GHz
In/Out Imped. ⁽¹⁾	Ant, J1, J2, J3, J4		50		Ω
Gain	Normal Configuration, Ant–Any Output, Unused Outputs- 50 Ω	17	18.4	19	dB
	Hi Isolation Config, Ant – Any Output, Unused Outputs - 50 Ω	1.5	3.0	4	dB
Input SWR	All ports - 50 Ω			2.0:1	-
Output SWR	Normal Configuration , All ports - 50 Ω			1.8:1	-
	Hi Isolation Config, All ports - 50 Ω			1.3:1	-
Noise Figure	Normal Config., Ant – Any Output, Unused Outputs - 50 Ω		4.2	4.5	dB
	Hi Isolation Config, Ant – Any Output, Unused Outputs - 50 Ω		4.4	4.7	dB
Gain Flatness	L1 – L2 ; Ant – Any Output, Unused Outputs - 50 Ω		0.3	1	dB
Amplitude Ballance	J1 – J2 ; Ant – Any Output, Unused Outputs - 50 Ω			0.5	dB
Phase Ballance	Phase (J1 – J2) ; Ant – Any Output, Unused Outputs - 50 Ω			1.0	deg
Isolation	Normal Config., Adjacent Ports, Ant - 50 Ω (see plots)	10			dB
	Hi Isolation Config, Adjacent Ports, Ant - 50 Ω (see plots)	40			dB
Group delay Flatness	$\tau_{d,max} - \tau_{d,min}$: Ant – J1, J2 - 50 Ω ; Ant – J2, J1 - 50 Ω			1	ns
Req. DC Input V.	Non-Network Configuration, DC Input on J1	3.6		15	Vdc
Current ⁽²⁾	Amplifier Current Draw, All ports - 50 Ω			15	mA

(1). Input/Output Impedance = 75 Ω for 75 Ω connector option.

(2). Current draw on input DC port in the non-networked configuration.

Available Options

Network Power Supply		
Source Voltage Options	VOLTAGE INPUT	STYLE
	110VAC	Transformer (Wall Mount)
	220 VAC	Transformer (Wall Mount)
	240 VAC (United Kingdom)	Transformer (Wall Mount)
	Customer Supplied DC 8-28 VDC	Military Style Connector
Output Voltage Options ⁽¹⁾	DC VOLTAGE OUT	MAX CURRENT OUT FOR CORRESPONDING V _{out} ⁽²⁾
	5 V	110mA
	7.5V	130mA
	9V	140mA
	12V	170mA
	15V	210mA
	Custom	TDB
Output Port Isolation Options		
Isolation Options	Normal Isolation, 16dB min. Output Port – to – Output Port	
	High Isolation, 42dB min. Output Port – to – Output Port	
Pass/Block DC Options		
Pass DC ⁽¹⁾	All Ports Pass DC	
DC Blocked ⁽¹⁾	J2 is DC blocked, Pass DC from J1 to ANT.	
RF Connector Options		
Connector Options	CONNECTOR STYLE	CHARGE
	Type N	NC
	Type SMA	NC
	Type TNC	NC
	Type N - 75Ω	Contact Sales Agent

(1). With Network Option, any RF port (input or output) can be DC blocked or can pass the network DC voltage.

(2). T_A = +50°C. Assuming Source of 110V or 220V Wall Mount Transformer. In general, maximum output current can be determined by:

$$I_{out} \leq 2.9 / (V_{sourceDC} - V_{out}) \text{ A}$$

Part Number

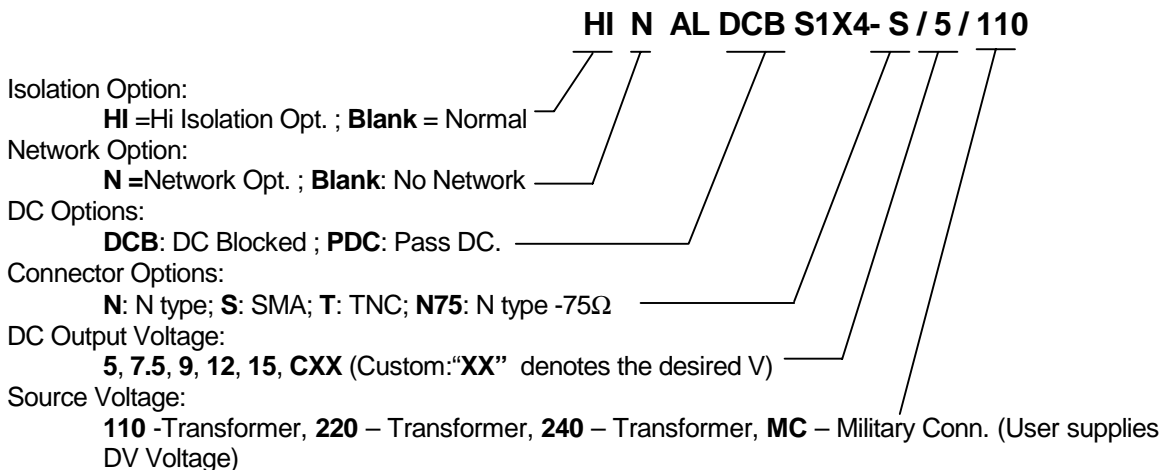

Performance

ALDCBS1X4 (Normal Output Isolation Option):

Input SWR (Ant. Port) and Frequency Response: Ant. To J1,J2,J3,J4 (Typical, type N conn.):

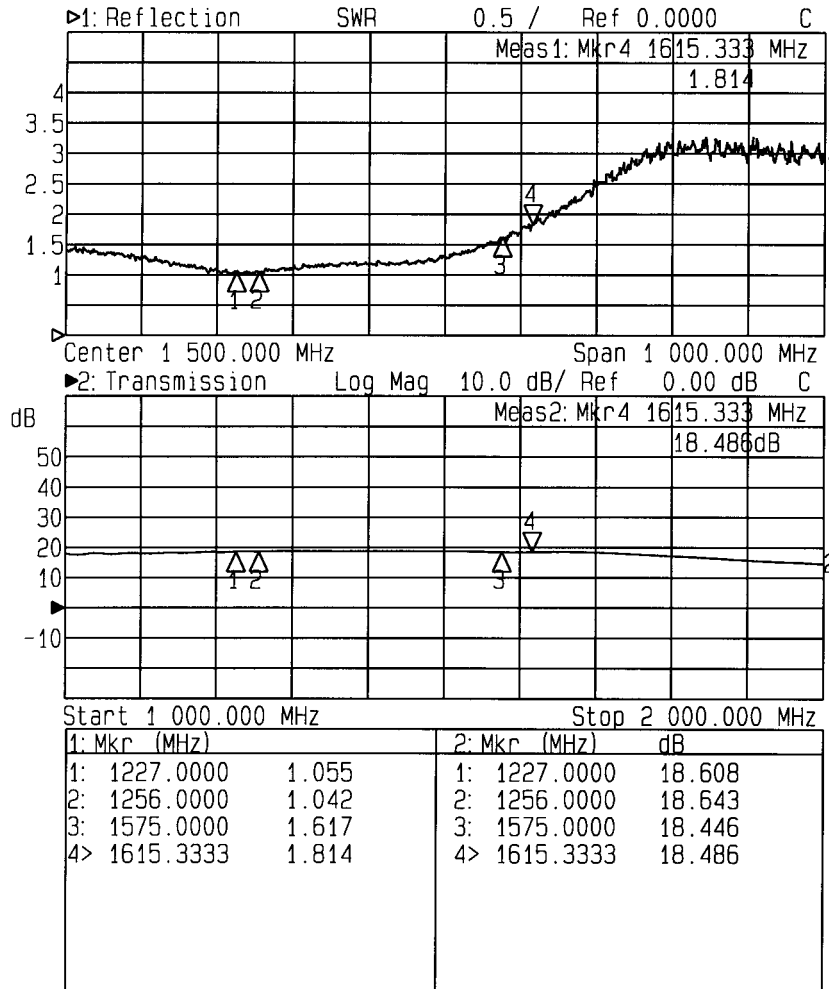

ALDCBS1X4 (Normal Output Isolation Option) (continued):

Output SWR (J1,J2,J3,J4) and Adjacent Output Isolation (J1-J3,J2-J4) (Typical, type N conn.):

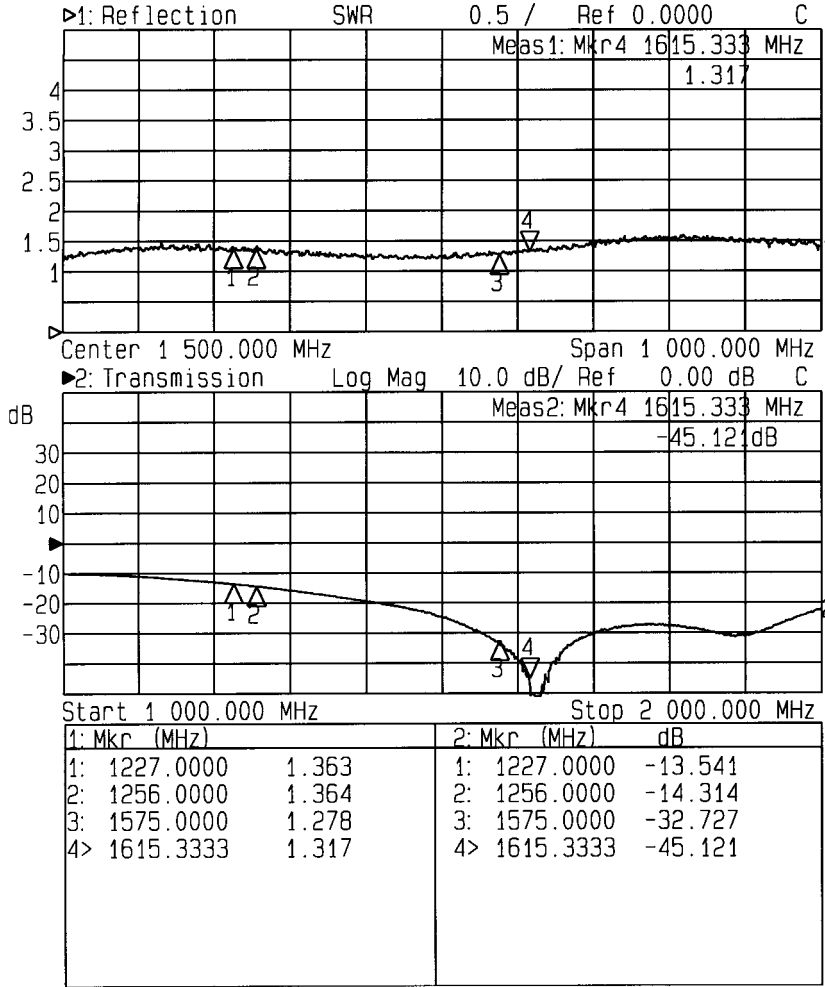

ALDCBS1X4 (Normal Output Isolation Option) (continued):

Opposite Output Isolation (J1-J2,J3-J4) (Typical, type N conn.):

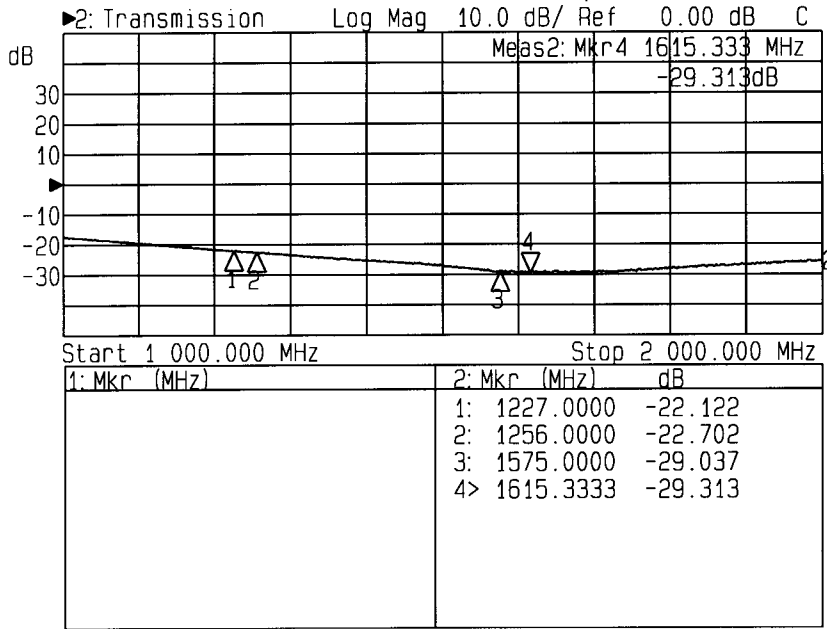

HIALDCBS1X4 (Hi Output Isolation Option):

Input SWR (Ant. Port) and Frequency Response: Ant. To J1,J2,J3,J4 (Typical, type N conn.):

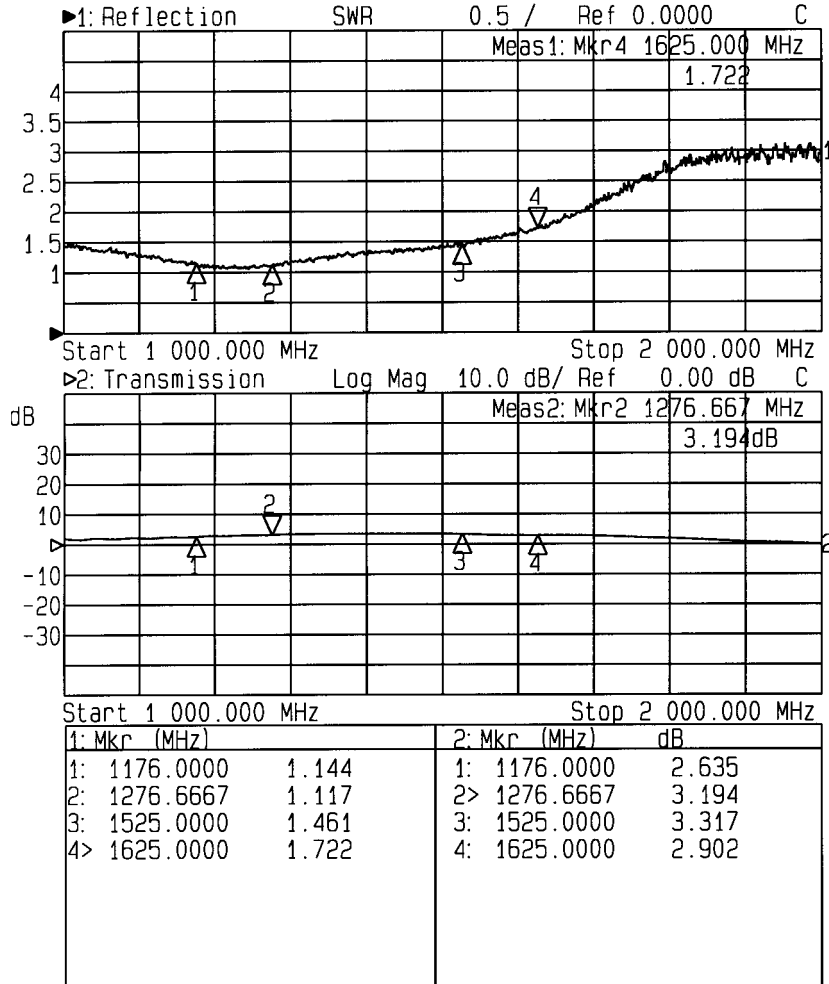

HIALDCBS1X4 (Hi Output Isolation Option) (continued):

Output SWR (J1,J2,J3,J4) and Adjacent Output Isolation (J1-J3,J2-J4) (Typical, type N conn.):

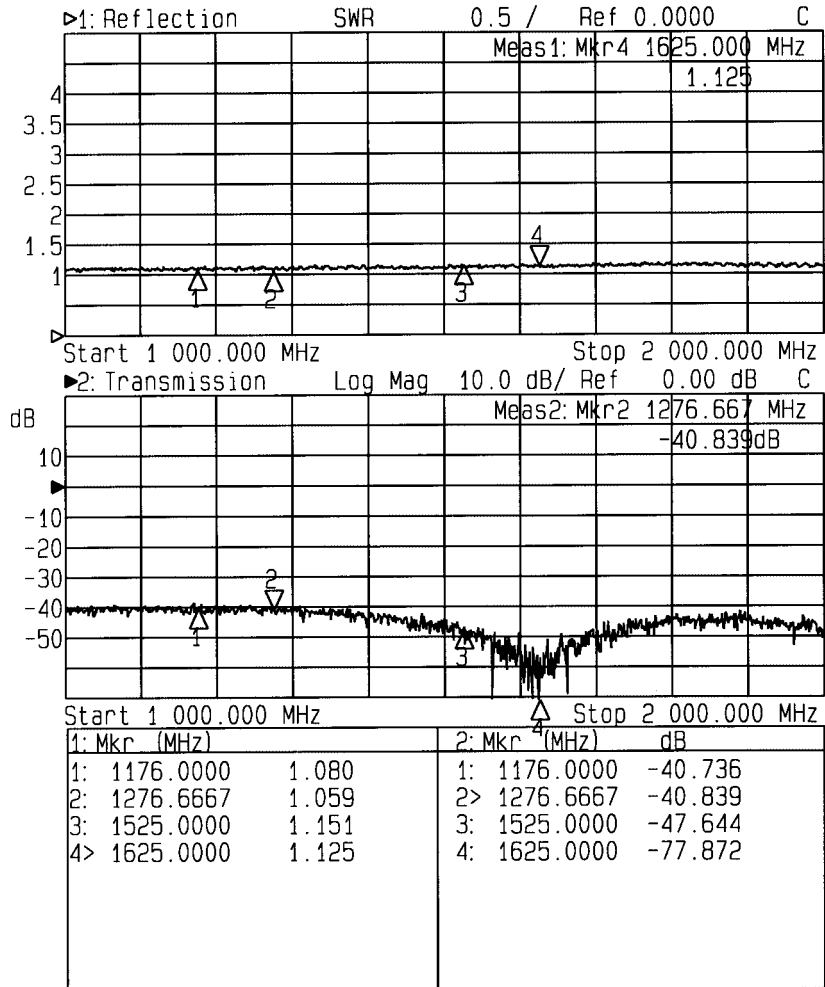

ALDCBS1X4 (Hi Output Isolation Option) (continued):

Opposite Output Isolation (J1-J2,J3-J4) (Typical, type N conn.):

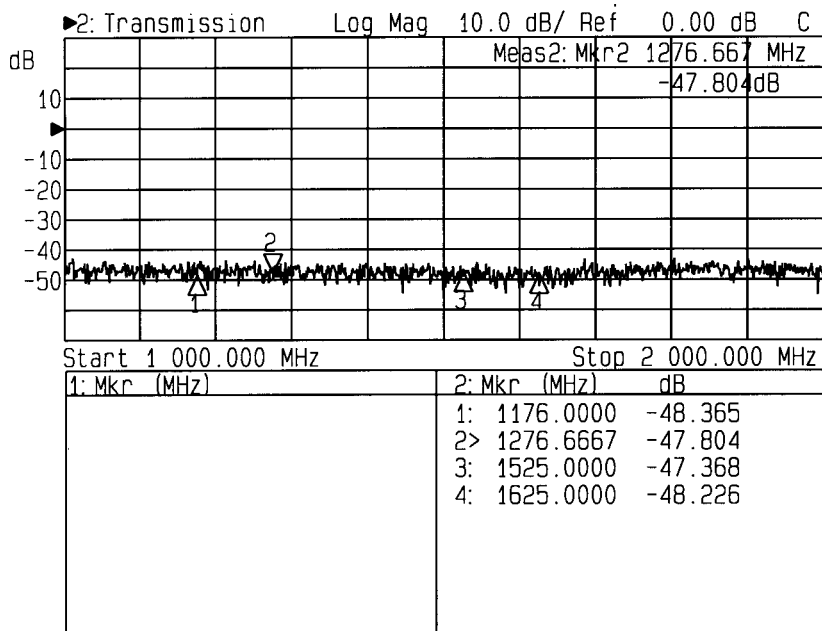

Mechanical

Dimensions:

Height: 1.3"

Length (not including connectors) Body: 2.5"
Base Plate: 3.25"

Width (not including connectors): 2.5"

Weight:

10 oz. (286 grams)

Operating Temp. Range: -40° to + 75°C