

ALDCBS1X2

Technical Product Data

Features

- **Amplifier Gain of 20dB**
Gain \geq 20dB
- **Extremely Flat Group Delay**
Less than 1ns variation
- **Phase Matched Outputs**
Phase (J1 – J2) $<$ 1.0°

Description

The ALDCBS1X2 GPS Amplified Splitter is a one input, two output device with a 20dB min. gain block. The frequency response covers the GPS L1 & L2 bands with excellent gain flatness. In the normal configuration, one of the splitter RF outputs (J1) passes DC from the connected GPS receiver through the splitter to the antenna, allowing the GPS receiver to power both the antenna and the splitter amp. The other RF output (J2) is DC loaded with a 200Ω resistor to simulate the antenna current draw.

Electrical Specifications, $T_A = 25^{\circ}\text{C}$

Parameter	Conditions	Min	Typ	Max	Units
Freq. Range	Ant – J1, J2 - 50Ω ; Ant – J2, J1 - 50Ω	1.1		1.7	GHz
In/Out Imped. ⁽¹⁾	Ant, J1, J2		50		Ω
Gain	Normal Configuration, Ant – J1, J2 - 50Ω ; Ant – J2, J1 - 50Ω	20	22	24	dB
	Hi Isolation Config, Ant – J1, J2 - 50Ω ; Ant – J2, J1 - 50Ω	4	6	8	dB
Input SWR	All ports - 50Ω			2.0:1	-
Output SWR	Normal Configuration , All ports - 50Ω			1.8:1	-
	Hi Isolation Config, All ports - 50Ω			1.5:1	-
Noise Figure	Normal Configuration, Ant – J1, J2 - 50Ω ; Ant – J2, J1 - 50Ω		3.3	3.5	dB
	Hi Isolation Config, Ant – J1, J2 - 50Ω ; Ant – J2, J1 - 50Ω		3.6	4.0	dB
Gain Flatness	L1 – L2 ; Ant – J1, J2 - 50Ω ; Ant – J2, J1 - 50Ω		0.5	1	dB
Amplitude Balance	J1 – J2 ; Ant – J1, J2 - 50Ω ; Ant – J2, J1 - 50Ω			0.5	dB
Phase Balance	Phase (J1 – J2) ; Ant – J1, J2 - 50Ω ; Ant – J2, J1 - 50Ω			1.0	deg
Isolation	Normal Configuration, J1 – J2, Ant - 50Ω	16		30	dB
	Hi Isolation Config, J1 – J2, Ant - 50Ω	42		63	dB
Group delay Flatness	$\tau_{d,max} - \tau_{d,min}$: Ant – J1, J2 - 50Ω ; Ant – J2, J1 - 50Ω			1	ns
Req. DC Input V.	Non-Network Configuration, DC Input on J1	3.6		15	Vdc

Current ⁽²⁾	Amplifier Current Draw, All prots - 50Ω			15	mA
------------------------	---	--	--	----	----

(1). Input/Output Impedance = 75Ω for 75Ω connector option.

(2). Current draw on input DC port in the non-networked configuration.

Available Options

Network Power Supply		
Source Voltage Options	VOLTAGE INPUT	STYLE
	110VAC	Transformer (Wall Mount)
	220 VAC	Transformer (Wall Mount)
	240 VAC (United Kingdom)	Transformer (Wall Mount)
	Customer Supplied DC 8-28 VDC	Military Style Connector
Output Voltage Options ⁽¹⁾	DC VOLTAGE OUT	MAX CURRENT OUT FOR CORRESPONDING Vout ⁽²⁾
	5 V	110mA
	7.5V	130mA
	9V	140mA
	12V	170mA
	15V	210mA
	Custom	TDB
Output Port Isolation Options		
Isolation Options	Normal Isolation, 16dB min. Output Port – to – Output Port	
	High Isolation, 42dB min. Output Port – to – Output Port	
Pass/Block DC Options		
Pass DC ⁽¹⁾	All Ports Pass DC	
DC Blocked ⁽¹⁾	J2 is DC blocked, Pass DC from J1 to ANT.	
RF Connector Options		
Connector Options	CONNECTOR STYLE	CHARGE
	Type N	NC
	Type SMA	NC
	Type TNC	NC
	Type N - 75Ω	Contact Sales Agent

(1). With Network Option, any RF port (input or output) can be DC blocked or can pass the network DC voltage.

(2). T_A = +50°C. Assuming Source of 110V or 220V Wall Mount Transformer. In general, maximum output current can be determined by:

$$I_{out} \leq 2.9 / (V_{sourceDC} - V_{out}) \text{ A}$$

Part Number

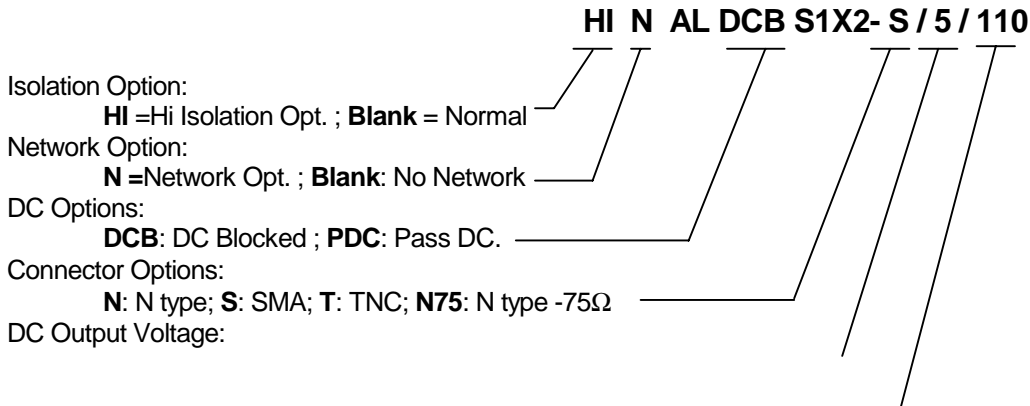

5, 7.5, 9, 12, 15, CXX (Custom: "XX" denotes the desired V) ———
 Source Voltage:
 110 -Transformer, 220 – Transformer, 240 – Transformer, MC – Military Conn. (User supplies DV Voltage)

Performance

ALDCBS1X2 (Normal Output Isolation Option):

Input SWR (Ant. Port) and Frequency Response: Ant. To J1, J2 (Typical, type N conn.):

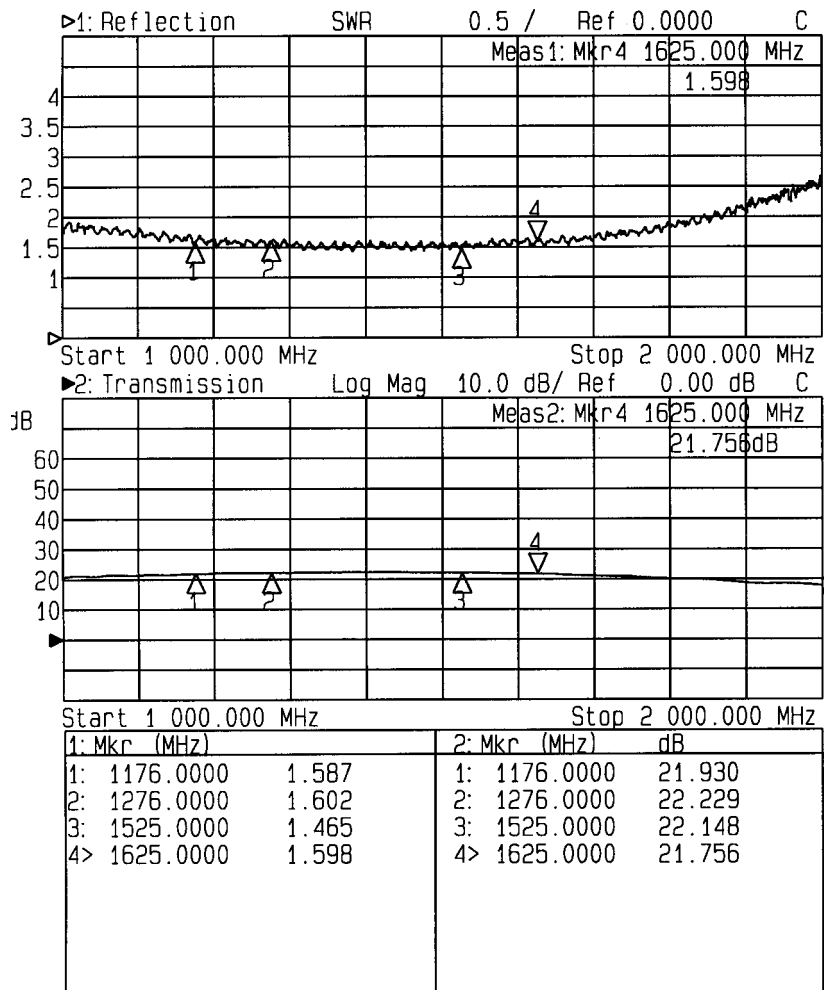

ALDCBS1X2 (Normal Output Isolation Option) (continued):

Output SWR (J1, J2) and Output – to – Output Isolation (S23, S32) (Typical, type N conn.):

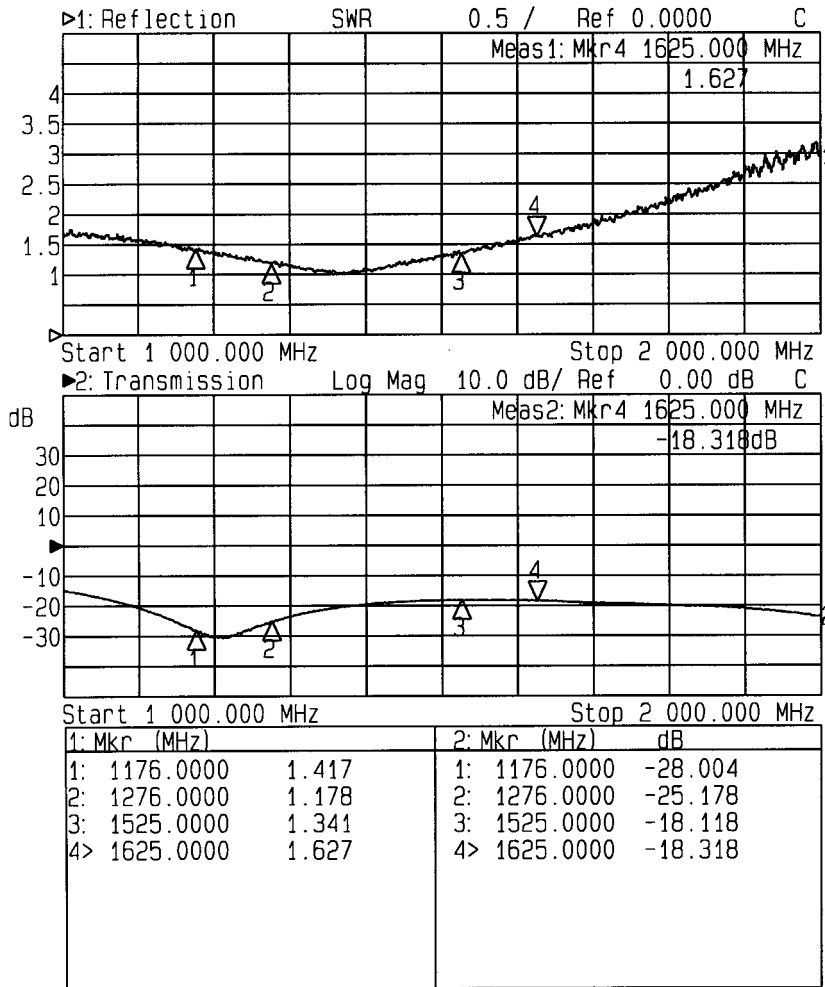

HIALDCBS1X2 (Hi Output Isolation Option):

Input SWR (Ant. Port) and Frequency Response: Ant. To J1, J2 (Typical, type N conn.):

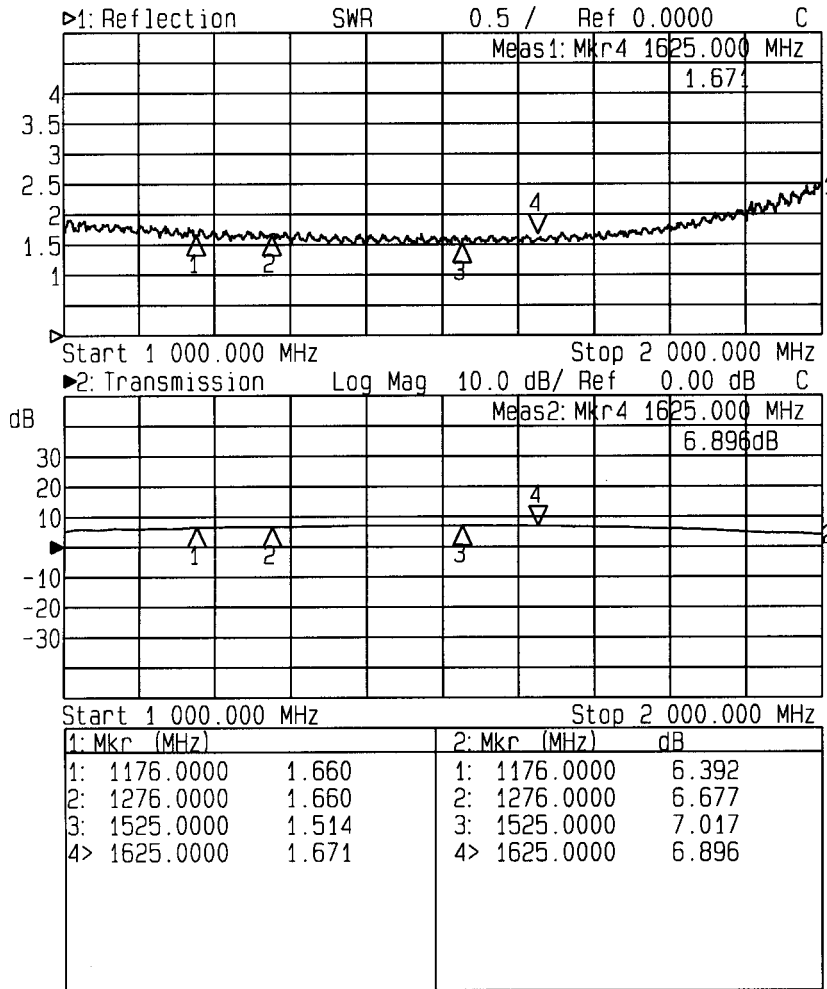

HIALDCBS1X2 (Hi Output Isolation Option) (continued):

Output SWR (J1, J2) and Output – to – Output Isolation (S23, S32) (Typical, type N conn.):

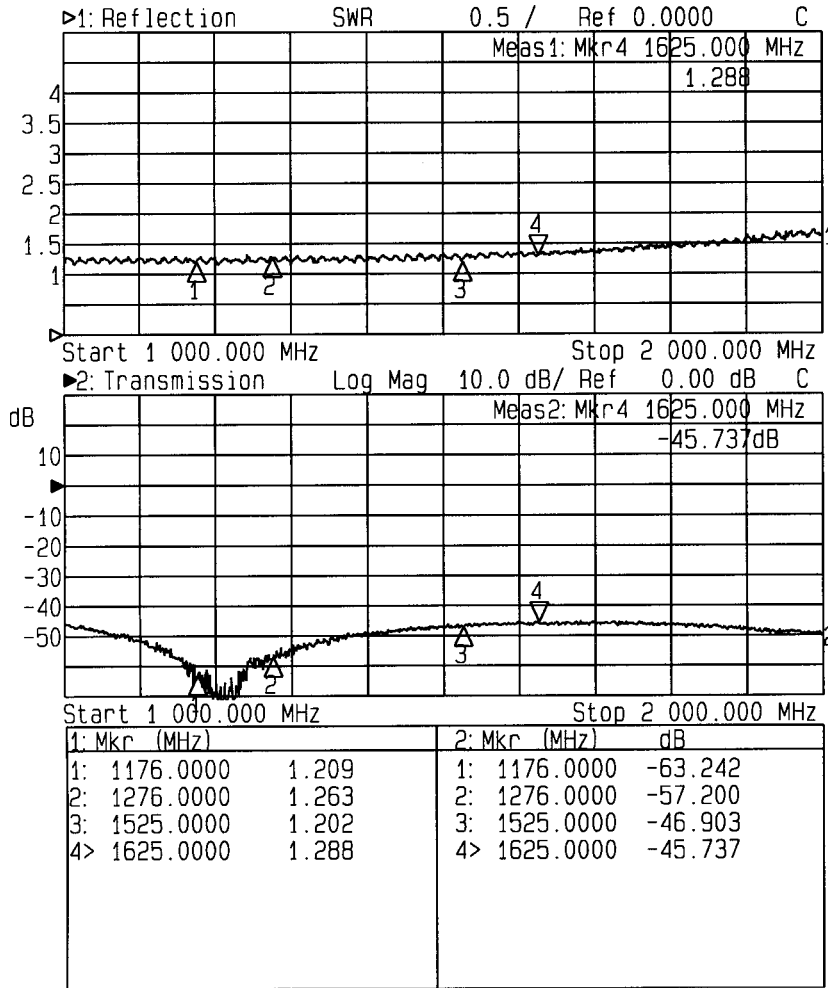

Mechanical

Dimensions:

Height: 1.3"

Length (not including connectors) Body: 2.5"
Base Plate: 3.25"

Width (not including connectors): 2.5"

Weight:

10 oz. (286 grams)

Operating Temp. Range: -40° to + 75°C

